

名称	EM11 110形 W230 昼白色 13,400lmタイプ	
型番	EM11SB-B8N13BF9-A	
光源	型番	-
	全光束	- [lm] -
保守率 (40,000h)	良い	0.88
	普通	0.86
	悪い	0.81
効率	上半球	1.1 [%]
	下半球	98.9 [%]
	全方向	100.0 [%]
器具光束		13,400 [lm]

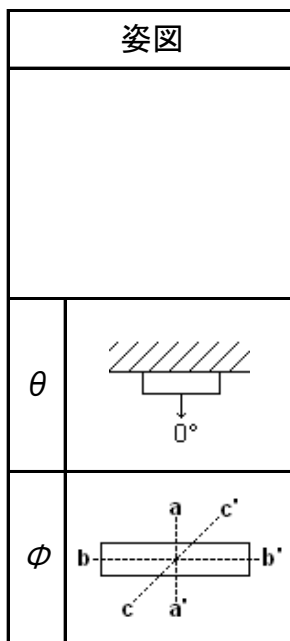

$\theta$	$\phi$	a-a'	b-b'	c-c'
0°		304	304	304
10°		299	296	298
20°		286	282	283
30°		263	256	259
40°		233	218	226
50°		197	172	186
60°		160	123	144
70°		122	77	103
80°		87	39	67
90°		57	12	38
100°		33	0	17
110°		16	0	0
120°		0	0	0
130°		0	0	0
140°		0	0	0
150°		0	0	0
160°		0	0	0
170°		0	0	0
180°		0	0	0

照明率表

反射率 (%)	天井		80						70						50				30		20	0		
	壁	床	70		50		30		70		50		30		50		30		30		10	0		
			30	10	30	10	30	10	30	10	30	10	30	10	30	10	30	10	30	10	10	0		
室指数	照明率 (×0.01)																						初期値	
0.6	60	56	45	43	36	35	58	54	44	42	36	35	43	41	35	34	34	33	29	27	29	27		
0.8	71	64	56	52	46	44	68	63	54	51	45	43	52	49	44	43	42	41	36	34	36	34		
1	79	71	64	60	54	51	76	69	62	58	53	51	59	56	51	49	49	48	43	41	43	41		
1.25	86	77	72	66	62	59	83	75	70	65	61	58	67	63	59	56	57	55	50	47	50	47		
1.5	92	81	79	71	69	64	88	79	76	70	68	63	72	68	65	61	62	60	55	52	55	52		
2	100	87	89	79	80	73	96	85	86	78	78	72	80	75	74	70	70	68	63	61	63	61		
2.5	105	91	95	84	87	78	101	89	92	82	85	77	86	80	80	75	76	73	69	66	69	66		
3	109	94	100	88	92	82	105	92	97	86	90	81	90	83	85	79	80	77	73	70	73	70		
4	114	97	106	92	100	88	109	95	102	90	97	86	95	87	91	84	86	82	78	75	78	75		
5	117	99	110	95	105	91	112	97	106	93	101	90	99	90	95	87	89	85	81	78	81	78		
10	123	103	119	101	116	98	118	101	114	99	111	97	106	96	104	94	97	91	89	86	89	86		

配光曲線 (cd/1000[lm])

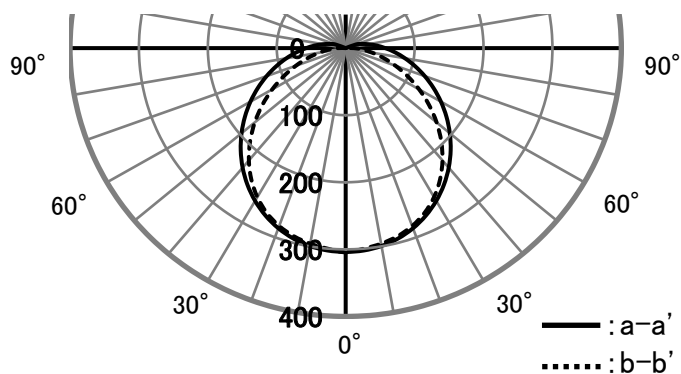

高さ(m) 直射水平面照度図 初期値

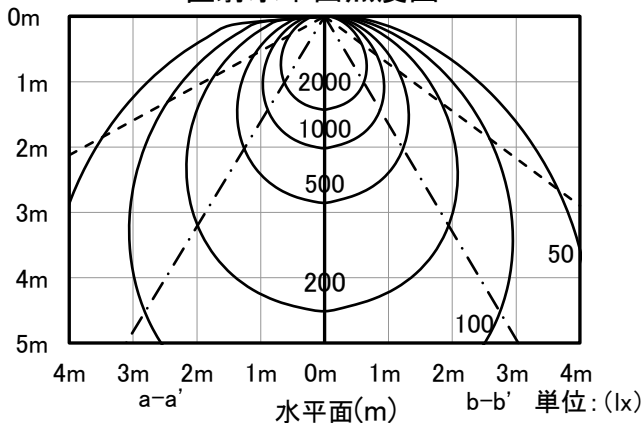

124°	1/2ビーム角---	108°
64°	1/2照度角---	63°